

Urban Water Security Research Alliance



The Complexities of Communal Rainwater Systems

Barry Hood

Ted Gardner, Ashok Sharma
Decentralised Systems Project

17 August 2009

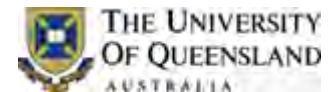

Water Savings Targets – Domestic



Queensland Development Code MP 4.2 – Potable water savings

- 70 kL / house / year (detached)
- 42 kL / residence/year (Semi detached)
- Rainwater tanks, Greywater systems or alternative water sources
- 100 m² connected roof area for tank

Capo Di Monte - Communal Rainwater System



Capo Di Monte - Communal Rainwater system



- North Tambourine, Gold Coast Hinterland
- 48 semi-detached residences
- 400 kL rainwater storage
- 200 kL active volume
- Treated Rainwater for all internal purposes except toilet flushing (recycled water)
- Backup bore supply

Capo Di Monte - Communal Rainwater system

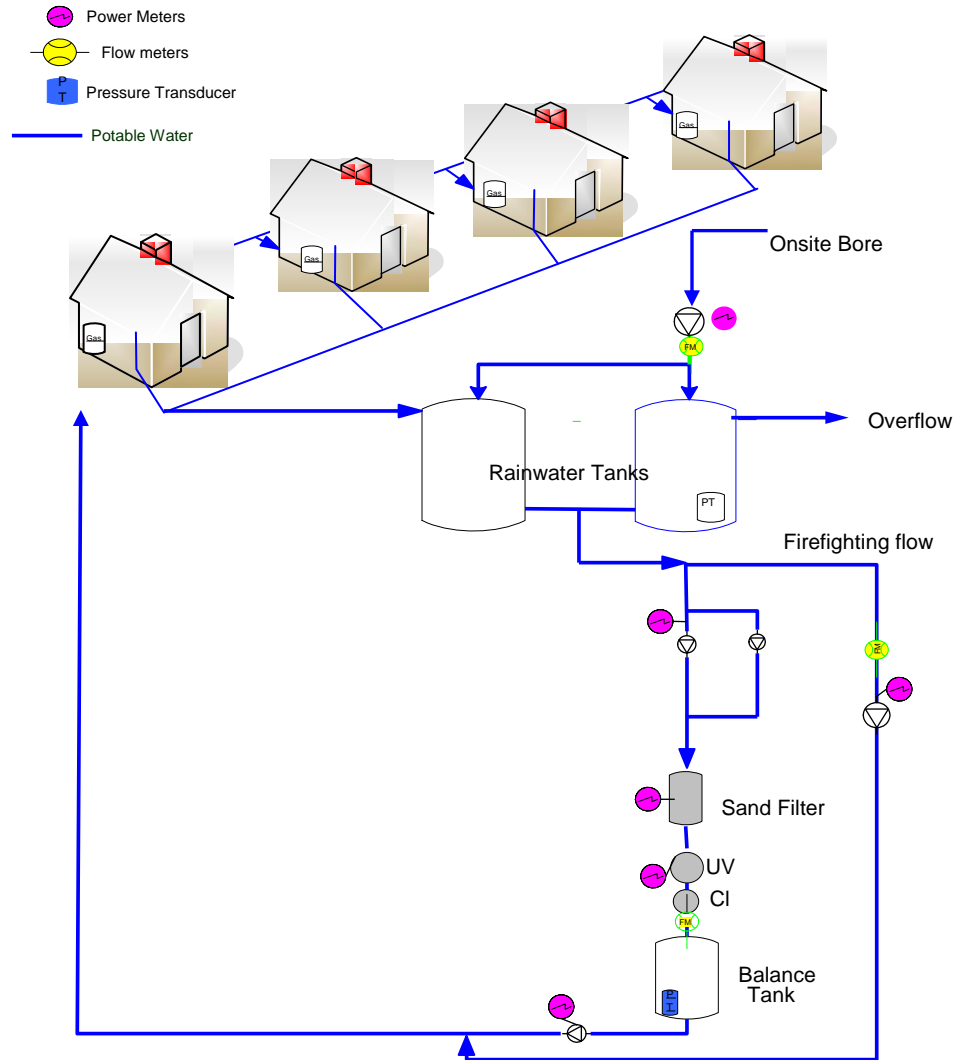

Hydraulic Circuit
of Potable Supply

Capo Di Monte - Communal Rainwater System

Rundown Screens to reduce leaf contamination to communal conveyance pipework

Recycled water outlet



Capo Di Monte - Communal Rainwater system



Meter for bore top-up

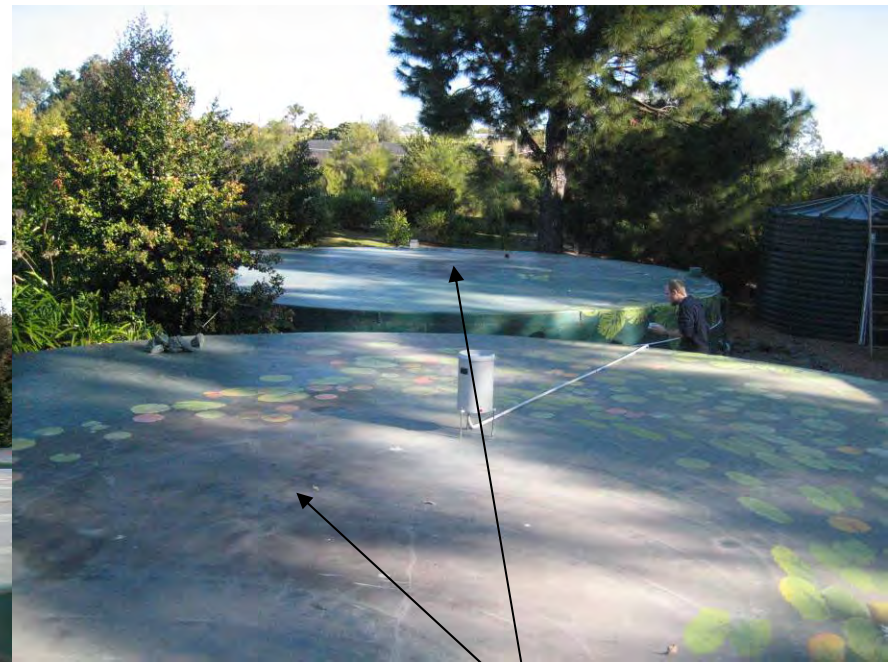

Rain Gauge

200 kL Rainwater storage tanks

Capo Di Monte - Communal Rainwater system



25 kL Balance Tank

Pumps

Sand filter

UV sterilisation

Chlorine dosing system

Capo Di Monte - Communal Rainwater system



Monitoring

- Rainfall
- Catch efficiency
- Volume supplied to residences
- Energy
 - Pumping – Distribution, (Bore)
 - Treatment - Sand filter, UV

H₂O Sampling

- Physico-chemical
- Microbiological

Modelling

- Conveyance hydraulics
- Catch efficiency

Water Savings Targets - Commercial

- Queensland Development Code MP 4.3 Commercial Buildings
- Alternative water sources required
- Rainwater, fire-fighting test water, chiller condensate (available)
- 1500 L storage for each *required pedestal*
- 50 m² connected roof area for each *required pedestal*
- Uses
 - *Toilet flush, irrigation, pool top-up, laundry (cold)*

Green Square North Tower



- Fortitude Valley, Brisbane
- 12 floors
- 6 star sustainability rating

Green Square North Tower

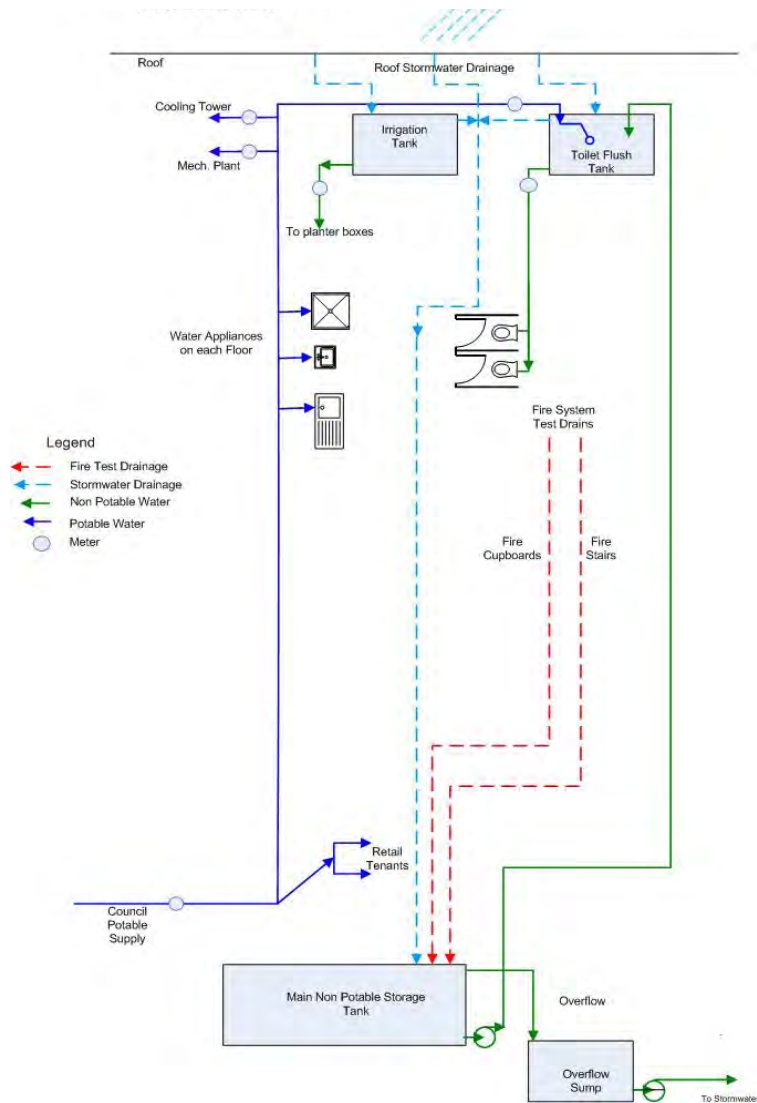

Sources:

Rainwater

Fire test flow

Chiller condensate

Uses:

Toilet flushing

Irrigation (minor)

Green Square North Tower



Base load gas powered generator

Green Square North Tower



Collection area

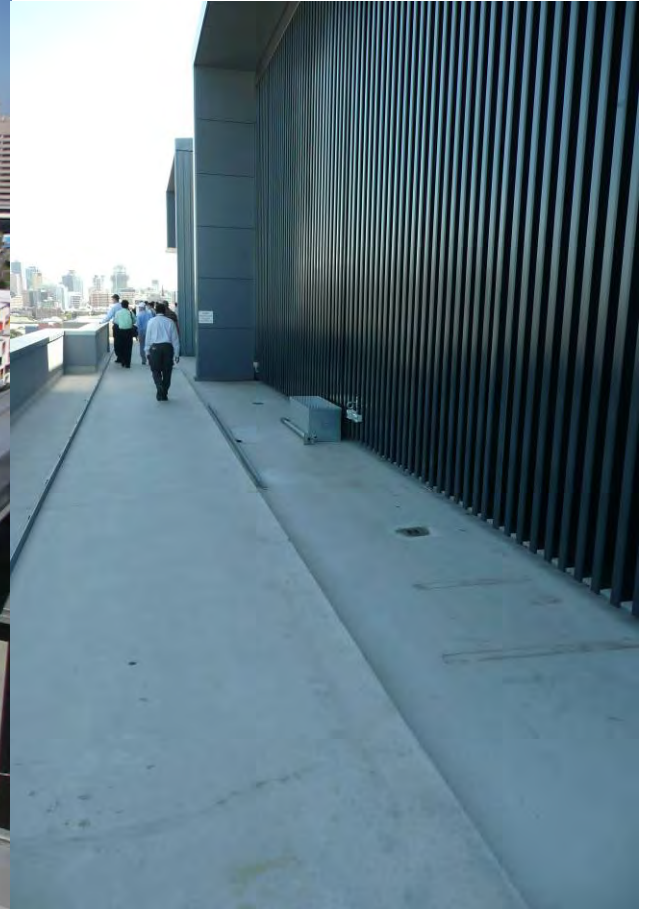

Drainage channel
and grates

Green Square North Tower



Gravity collection system in basement from multiple sources



Rainwater pumps in basement

Green Square North Tower



Monitoring

- Rainfall
- Catch efficiency
- Tank level (Basement)
- Supply To - Toilet, Irrigation
- Self sufficiency
- Pumping energy

Sampling

- Physico-Chemical,
- Microbiological

Communal Rainwater Systems



- Hydraulic efficiency up to 20yr ARI
- Demand
- Potable Substitution
- Specific energy of Treatment, Collection and Delivery
- Water Quality
- Capital and Operational Costs
- User Acceptance
- Alternative system design
- Opportunities for expansion of system (esp. GSNT)

Communal Rainwater Systems



- Modelling
 - DERM *TANK*
 - CSIRO *UVQ*
- Comparison and Projection
 - Coolum Ridge
 - Warnambool
 - Water Savings Targets for individual tanks

Urban Water Security Research Alliance



THANK YOU

www.urbanwateralliance.org.au

