

Urban Water Security Research Alliance



Decentralised vs. Centralised Water Cycle Options

Joe Lane

Ted Gardner, Murray Hall

Life Cycle Analysis and Integrated Modelling Project

18 August 2009



System Boundary

- Functional unit =
 - water cycle services for 109 lots (at the Currumbin site)
 - 50 yrs
- Construct → Use → ~~Disposal~~
- Marginal change for new 109 lots
- Impacts included
 - Freshwater extraction
 - Eutrophication potential
 - Global Warming potential
 - Resource depletion
 - Ecotoxicity

Analysis

- Normalisation against Australian totals
- Weightings sensitivity

Water Supply Analysis

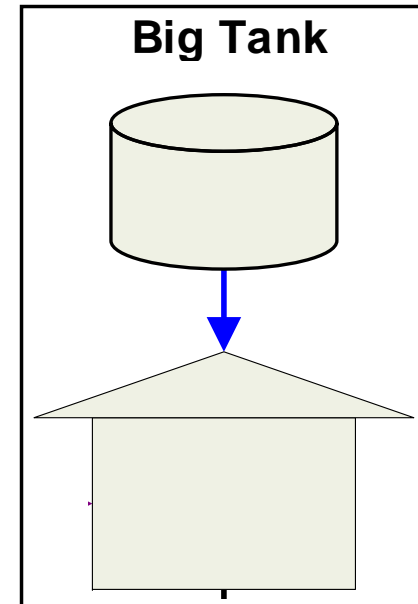
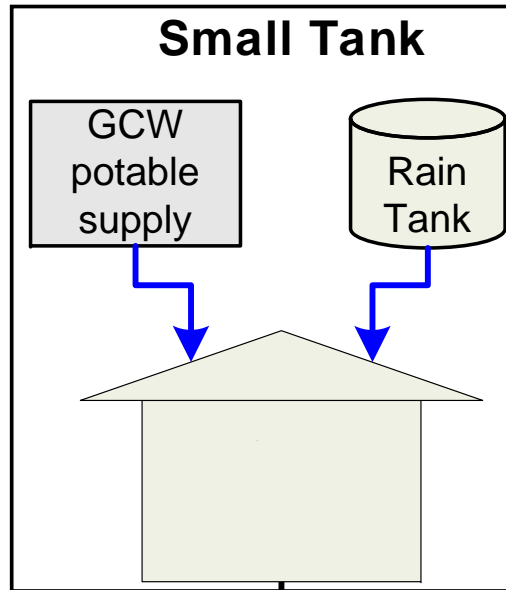
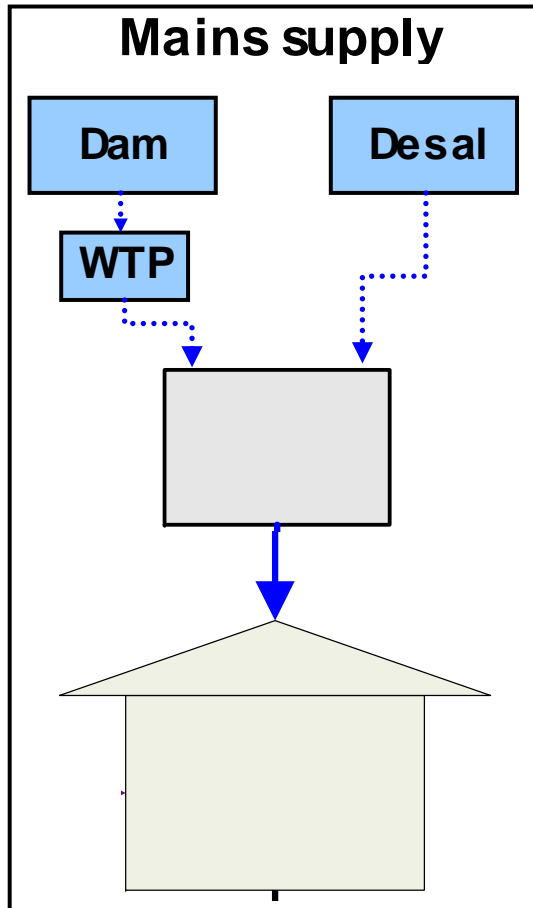

GCW

Water Supply Analysis

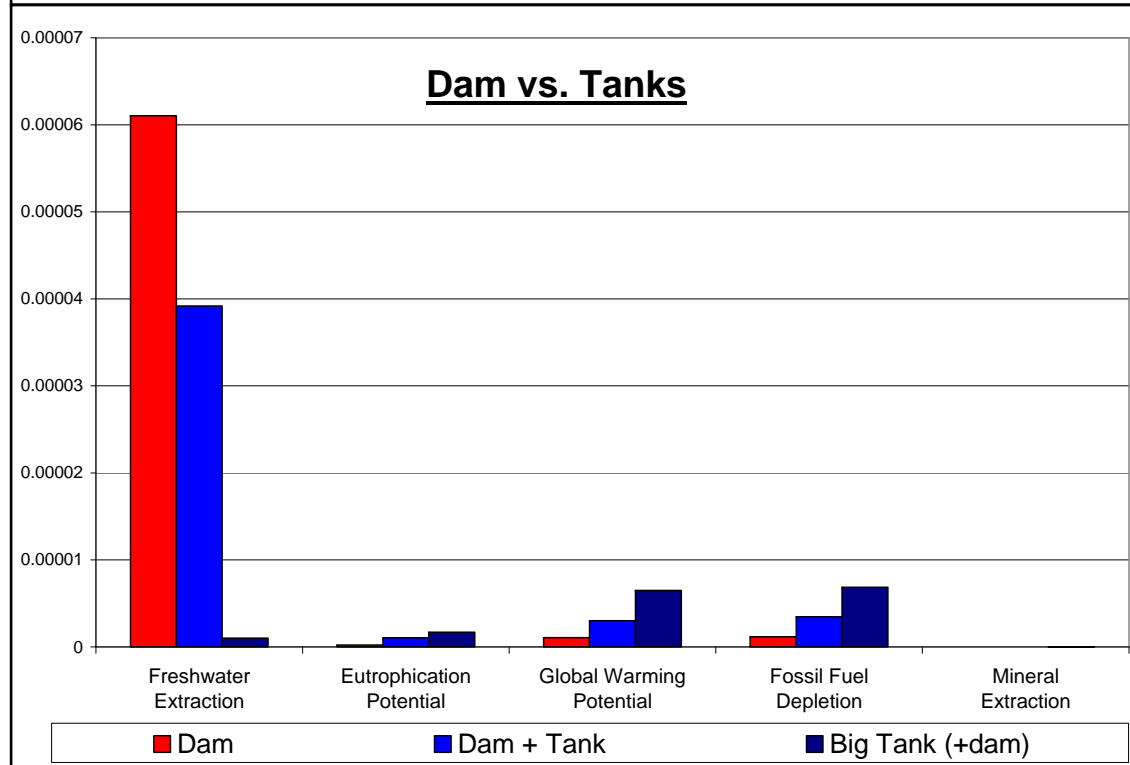
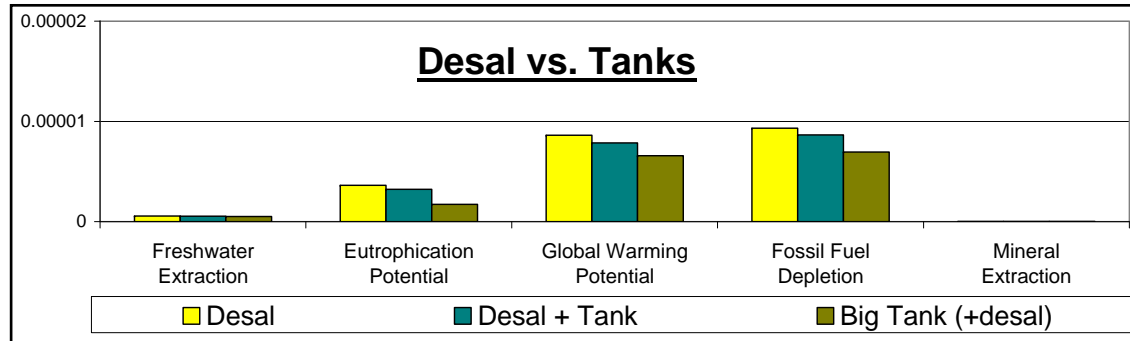

Water Supply Analysis

key uncertainties: Freshwater diversions

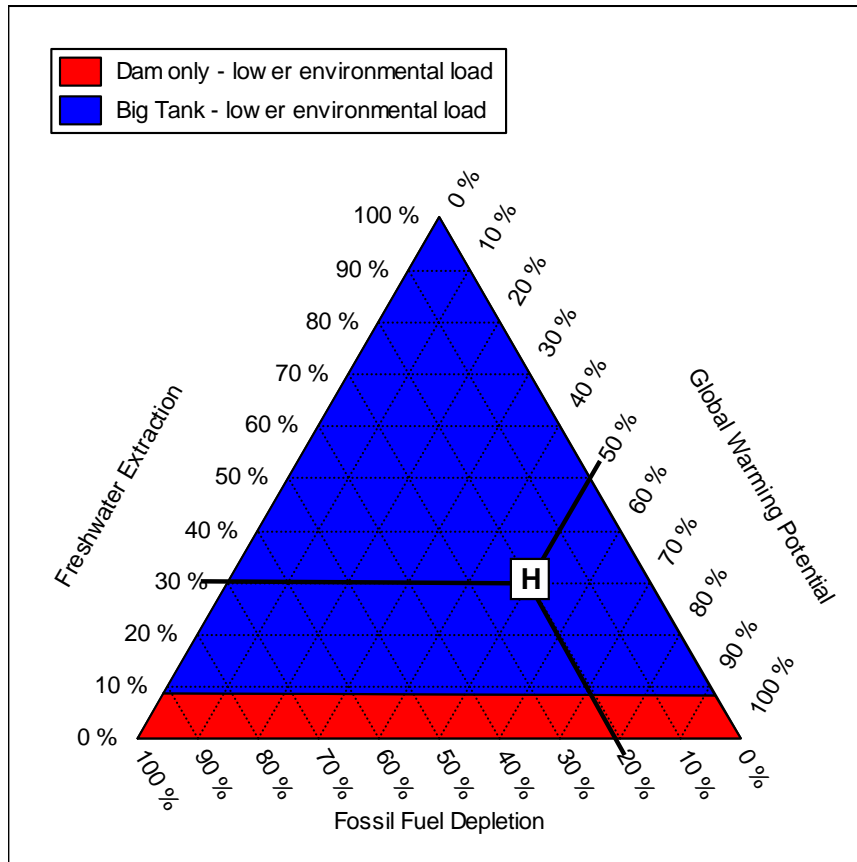

- marginal dam water use
 - is it important...?
- “it’s legal” argument
 - doesn’t work in LCA
- impact metric
 - scaled to ??
 - temporal aspects
- different freshwater sources
 - dam / river / creek / GW
- rainwater tank diversions
 - positive / negative / neutral

Water Supply Analysis

key uncertainties: Marginal grid supply

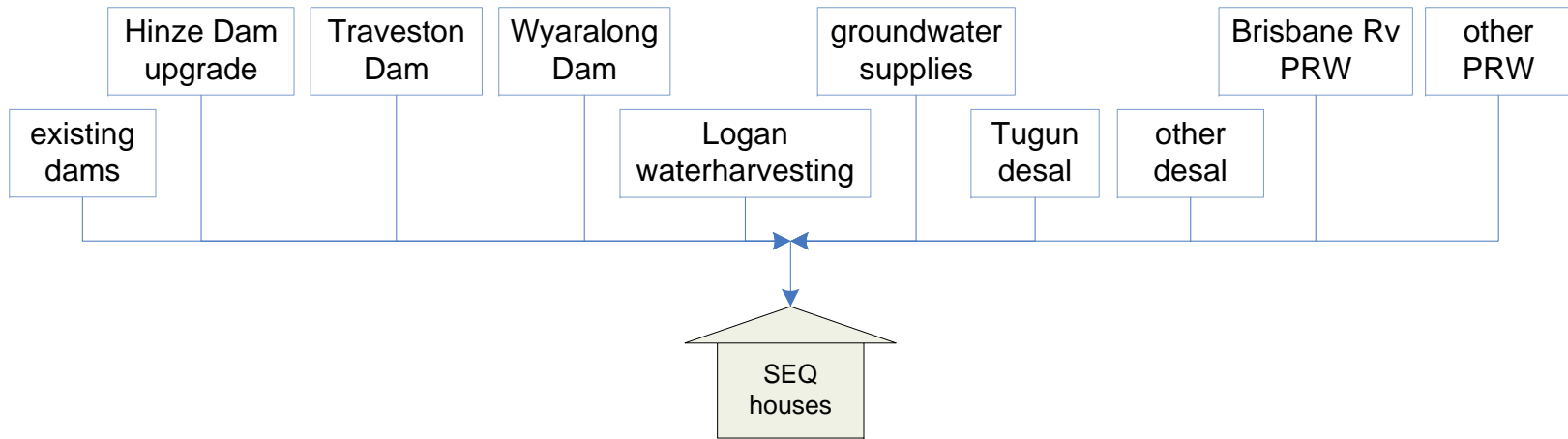

- marginal supply depends on:
 - Grid operating objectives
 - locality
 - which infrastructure is locked in
 - future variables
(eg: climate, demand growth)

- difficult to assess without an in-house tool

Water Supply Analysis

key uncertainties: Tank energy burden

Desalination

Energy Burden = f { __, __, __ }

- total HH demand
→ *well understood*
- avg production & supply energy
→ *engineered*

Rainwater Tanks

Energy Burden = f { __, __, __ }

- specific end use demands
→ *poorly understood*
→ *highly variable*
- roof & tank configurations
→ *highly variable*
- climate
→ *location dependent*
→ *future uncertainty*
- tank backup system
→ *significance varies*
- distribution energy
→ *limited data*
→ *large potential variation*

Wastewater Analysis

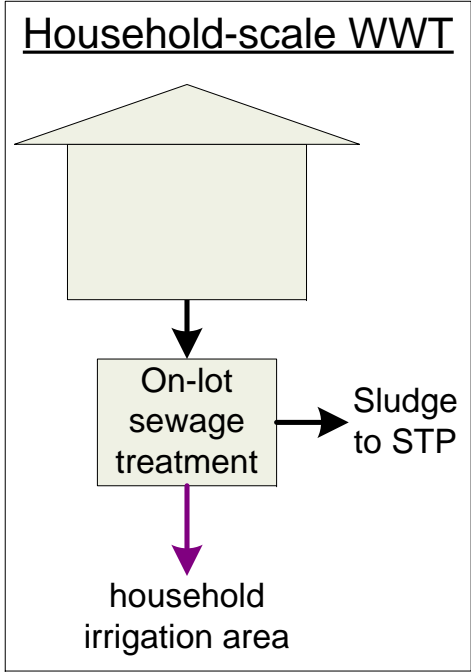
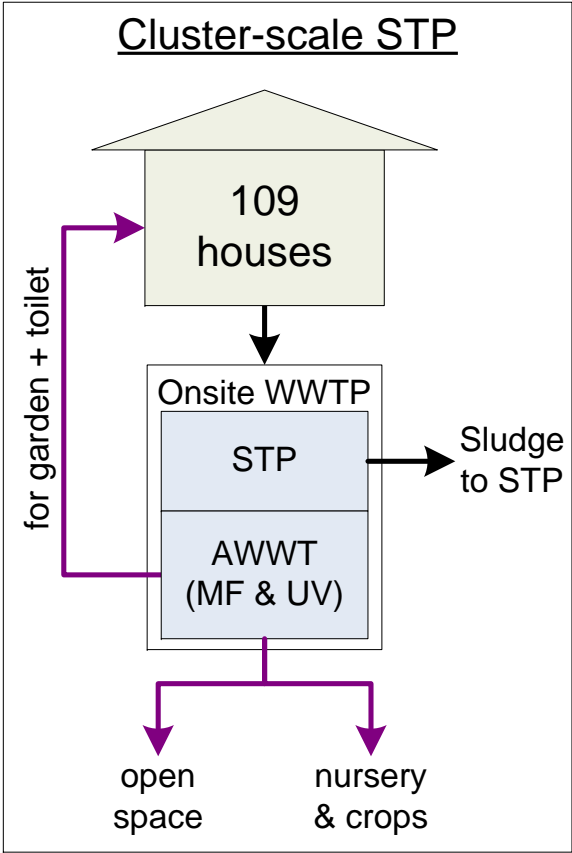
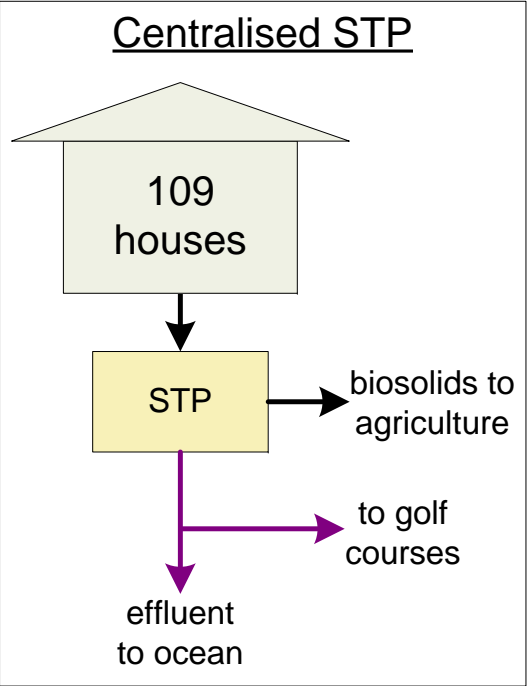

Wastewater Analysis

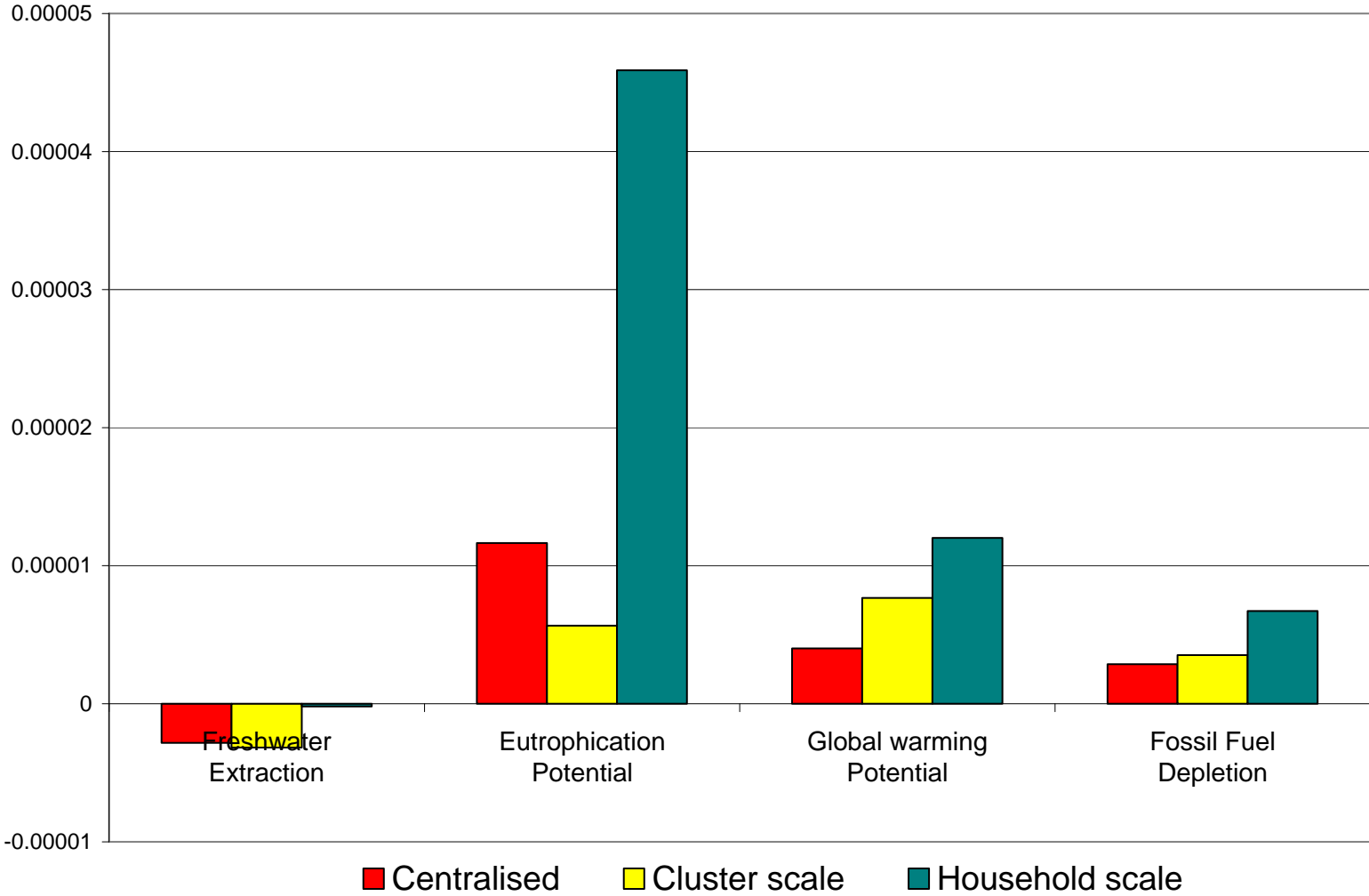

Wastewater Analysis

key uncertainties: Nutrient export

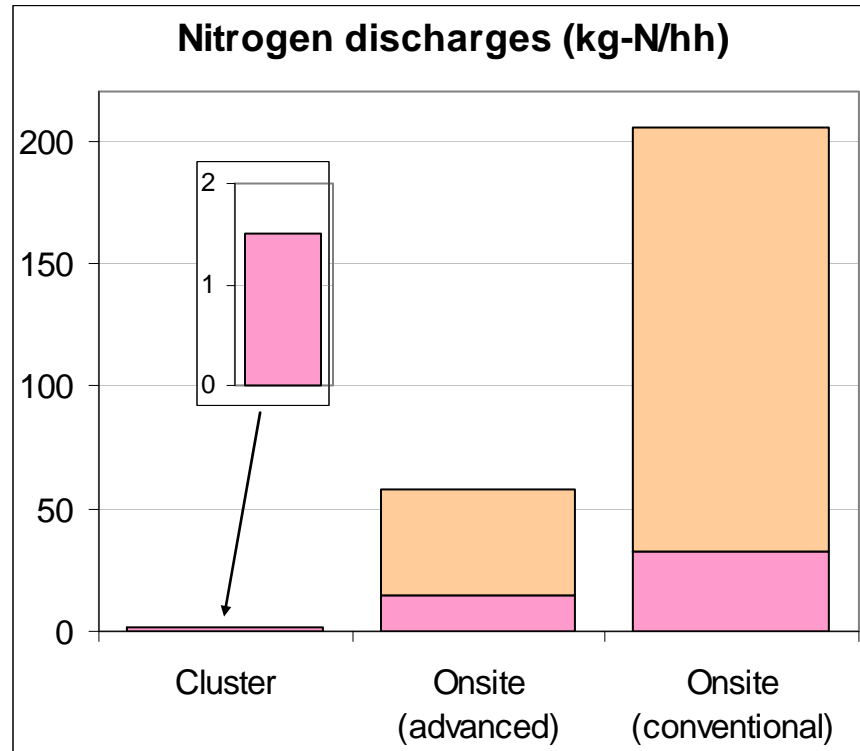

- STP discharge
 - well understood
- Irrigation export
 - very hard to predict & validate

Wastewater Analysis

key uncertainties: Energy use & Fugitive GHG

whole water cycle
(water supply + WWT) →

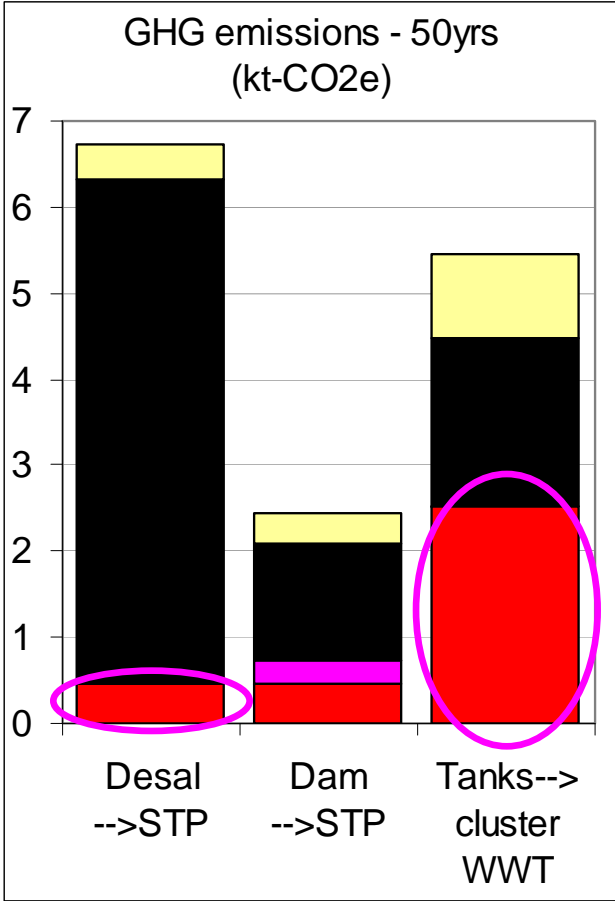
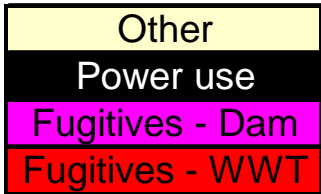

Wastewater Analysis

key uncertainties: Energy use & Fugitive GHG

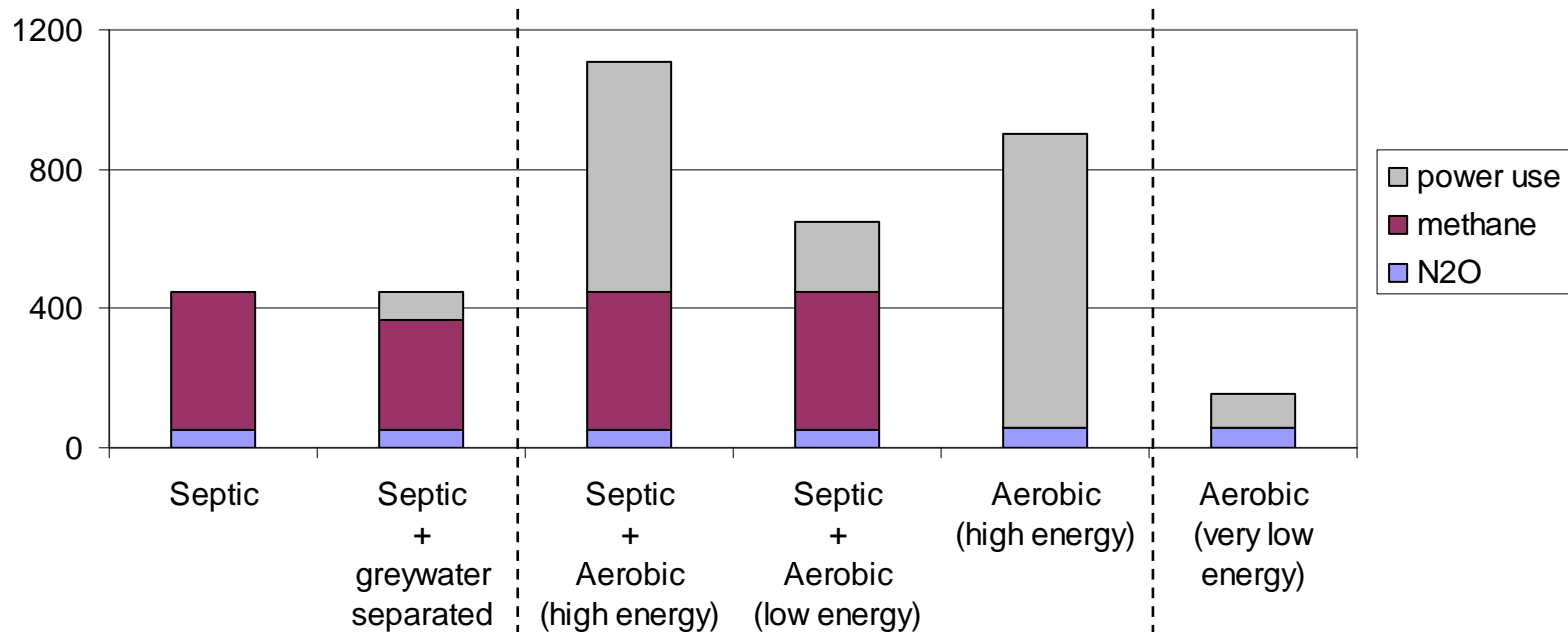

- N₂O uncertainty
 - bigger...?
 - more varied...?

- sewer Methane

- potential to capture gases

Conclusions

1. influential to decision making
 - Freshwater Extraction & Nutrient Discharge
 - rainwater tank advantages
 - cluster scale WWT can be competitive
2. GHG constraints on decentralised uptake
3. Key uncertainties to be addressed

Further Analysis

Screening studies

- environmental impacts of rainwater tanks
- optimal scale for WW treatment/reuse
- biosolids management

Opportunities for improvement

- detailed analysis of centralised infrastructure

Usefulness to decision makers

- normalisation
- impact metrics

Thank you

www.urbanwateralliance.org.au

and thanks to:

- Landmatters / The Ecovillage at Currumbin
- Gold Coast Water / QWC
- Dave de Haas / Jeff Foley (UQ)
- Tim Grant / Yarra Valley Water